

Eaton SB747S1915AFB

Catalog Number: SB747S1915AFB

Eaton B-Line series open frame racks, Aluminum, Includes #12-24 mounting hardware, Three mounting spaces required, 100 lb load capacity, Flat black powder coat, Single sided rack mounted shelf solid shelf

General specifications

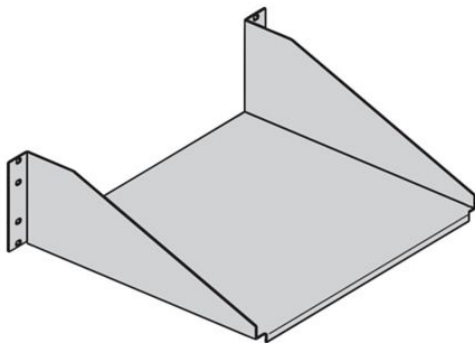

Product Name	Catalog Number
Eaton B-Line series open frame racks	SB747S1915AFB
UPC	Product Length/Depth
799038170488	15 in
Product Height	Product Width
5.19 in	18.31 in
Product Weight	Certifications
3.8 lb	Not Applicable

Product specifications

Special features

Three (3) mounting spaces required

Model

Single sided rack mounted shelf solid shelf

Material

Aluminum

Finish

Flat black powder coat

Resources

Brochures

[RCM and RCM+ brochure](#)

Specifications and datasheets

[Eaton Specification Sheet - SB747S1915AFB](#)



Eaton Corporation plc
Eaton House
30 Pembroke Road
Dublin 4, Ireland
Eaton.com
© 2023 Eaton. All Rights Reserved.

Eaton is a registered trademark.

All other trademarks are property of their respective owners.



[Eaton.com/socialmedia](https://www.eaton.com/socialmedia)